







240 litri raccolta umido

scheda tecnica | uso non domestico

prodotto	Sacco Sumus® a bocca aperta, con fondo crociato. Prodotto conforme al Decreto CAM (criteri ambientali minimi e premiali) servizi raccolta vigente.
materiali	Carta kraft avana riciclata 100% post consumo
grammatura	75+75 g/m ² (foglio doppio) 90 g/m ² (foglio singolo, a partire dal 240l)
colle e inchiostri	Colla a base d'acqua, inchiostro a base d'acqua di colore nero con pigmento in fibra di carbone.
certificazioni	<p>Compostabile CIC - UNI EN 13432:2002 HPB High Performance Bag - UNI EN 13593:2003 FSC® - Forest Stewardship Council CQ-COC-000217 ATICELCA® 501 - livello B</p>    

misure

l = litri | misure in cm

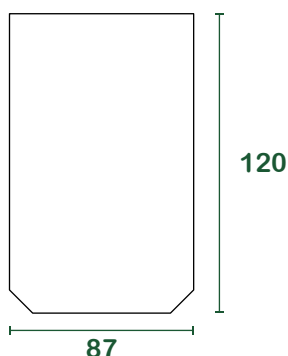
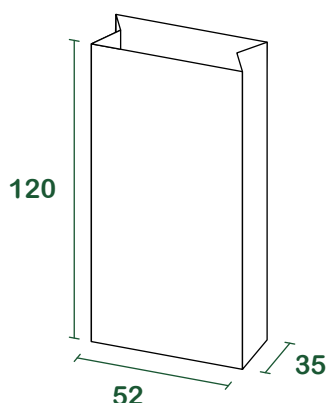

confezionamento

base [pz/mazzetta]	25
pz/paletta	2400
dim. paletta di carico [cm]	80X120X150
peso lordo paletta [kg]	1.250
carico completo [palette]	32
carico completo [pz]	79.200