

50 litres paper waste



technical data sheet

product Sumus® bag, flat bottom, self-shaped.

materials 100% recycled,
post consumer kraft paper

weight 75 g/m²

glues and inks Water - based.

certifications HPB High Performance Bag - UNI EN 13593:2003
FSC® - Forest Stewardship Council CQ-COC-000217
ATICELCA® 501 - livello B



size

l = litri | misure in cm

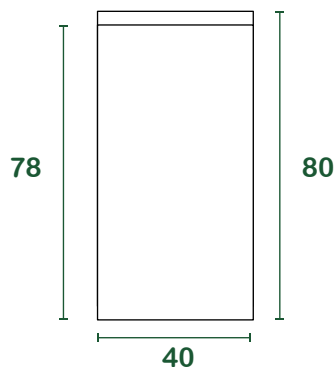
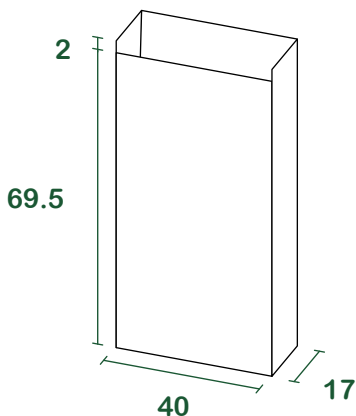

packaging

base [pieces/wad]	25 / 50 / 100
pieces/pallet	10.000
pallet size [cm]	80 _x 120 _x 175
gross weight pallet [kg]	610
full load [pallets]	32
full load [pieces]	320.000

